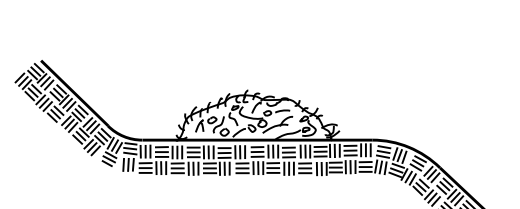
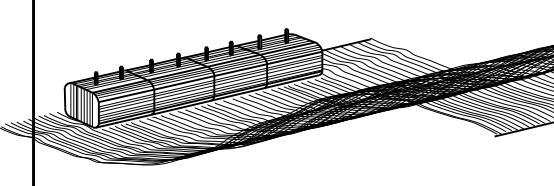
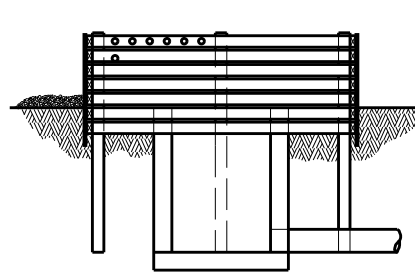
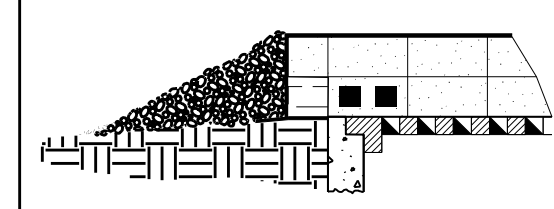
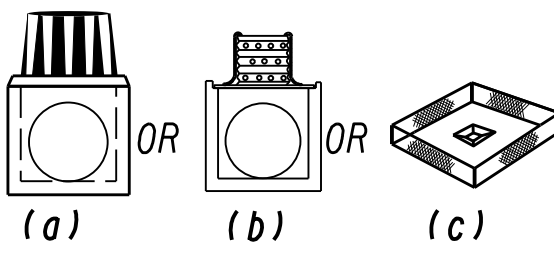
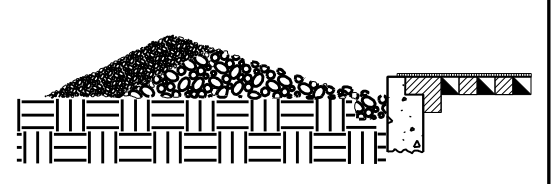
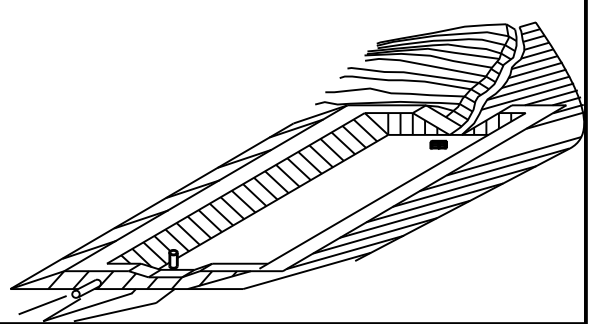
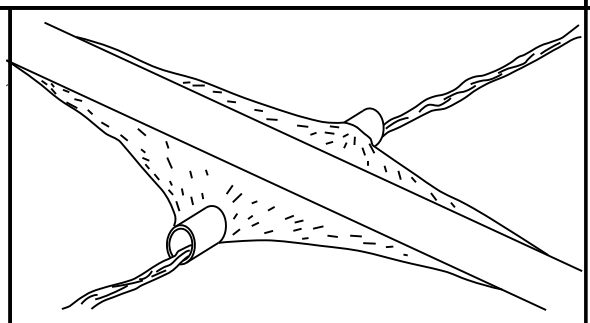

CODE	PRACTICE STD :SPC's :SECTION	DETAIL	DESCRIPTION
Sd1-Bb		<p>BRUSH BARRIER</p>  <p>CONSTRUCTION DETAIL</p> <p>LINE CODE</p> <p>* * * Sd1-Bb * * *</p>	<p>THIS ITEM CONSISTS OF INTERMINGLED BRUSH, LOGS, ETC. SO AS NOT TO FORM A SOLID DAM. CONSTRUCTED AT THE TOE OF FILL SLOPES DURING THE CLEARING AND GRUBBING OPERATION. THE BARRIER SHOULD BE USED AT THE TOE OF FILL SLOPES ON GRADING PROJECTS IN RURAL AREAS WHERE SUFFICIENT RIGHT OF WAY OR EASEMENT IS AVAILABLE (10 FEET OR MORE). THE BARRIER SHOULD RUN ROUGHLY PERPENDICULAR TO THE FLOW OF WATER WHERE THIS DOES NOT CONFLICT WITH RIGHT OF WAY OR EASEMENT LIMITS. THEY WILL NOT BE PLACED IN WETLANDS. PAYMENT FOR THIS ITEM IS INCLUDED IN THE CLEARING AND GRUBBING COST. NO SEPERATE PAYMENT SHALL BE MADE.</p>
Sd1-Hb		<p>SEDIMENT BARRIER</p>  <p>CONSTRUCTION DETAIL SECTION 163</p> <p>LINE CODE</p> <p>- s - s - s - Sd1-Hb - s - s - s -</p>	<p>A BARRIER OF BALED STRAW IS USED TO PREVENT SEDIMENT FROM LEAVING THE CONSTRUCTION SITE. IT IS USED IN DITCHES AS DITCH CHECKS OR ALONG THE TOE OF SLOPE OR RIGHT OF WAY IN FILLS LESS THAN 10 FEET HIGH. THE BALES SHOULD RUN PARALLEL TO THE SILT YIELDING AREA UNTIL THE TOP OF THE BALE IS 6 INCHES LOWER THAN THE GROUND ELEVATION OF THE BEGINNING BALE. THEY SHOULD THEN TURN INTO THE FILL WITH A LOW POINT FOR THE WATER TO DRAIN OVER THE BALE. IN DITCHES, BALED STRAW SHOULD BE PERPENDICULAR TO THE FLOW. USED FOR SLOPES LESS THAN 1%. USE 100' SPACING. BALED STRAW SHALL BE STAKED SECURELY TO THE GROUND.</p>
Sd2-B		<p>BAFFLE BOX INLET SEDIMENT TRAP</p>  <p>CONSTRUCTION DETAIL D42 SPECIFICATIONS SECTION 163</p> <p>LINE CODE</p> <p>Sd2-B</p>	<p>USED FOR INLETS RECEIVING RUNOFF WITH A HIGHER VOLUME OR VELOCITY. A GUIDE FOR USE WILL BE FOR AN INLET RECEIVING A Q=7 cfs.</p>
Sd2-Bg		<p>BLOCK & GRAVEL DROP INLET PROTECTION</p>  <p>CONSTRUCTION DETAIL D42 SPECIFICATIONS SECTION 163</p> <p>LINE CODE</p> <p>Sd2-Bg</p>	<p>USED FOR INLET PROTECTION WHERE HEAVY FLOWS ARE EXPECTED AND WHERE OVERFLOW CAPACITY IS NECESSARY TO PREVENT EXCESSIVE PONDING AROUND THE STRUCTURE. CAN BE USED AT CULVERT INLETS. A GUIDE FOR USE WILL BE FOR AN INLET RECEIVING A Q=5-7 cfs.</p>
Sd2-F		<p>INLET SEDIMENT TRAP</p>  <p>CONSTRUCTION DETAILS SECTION 163</p> <p>LINE CODE</p> <p>Sd2-F</p>	<p>(a) A SEDIMENT BARRIER CONSISTING OF A PREFABRICATED FRAME WITH FILTER FABRIC USED AROUND A DROP INLET OR CATCH BASIN (b) A SEDIMENT BARRIER CONSISTING OF A PERFORATED METAL STAND PIPE WITH FILTER FABRIC USED AROUND A DROP INLET OR CATCH BASIN (c) TYPE C SILT FENCE WITH SUPPORTING FRAME CAN BE USED AS AN ALTERNATE TO INLET SEDIMENT TRAP FOR AREAS WITH SLOPES < 5%.</p> <p>THIS ITEM IS USED TO PREVENT SILT FROM ENTERING THE PIPE SYSTEM. SHALL NOT APPLY TO INLETS RECIEVING CONCENTRATED FLOWS. RECOMMENDED FOR INLET RECEIVING FLOWS THAT RANGE FROM Q=0-4 cfs.</p>

CODE	PRACTICE STD :SPC's :SECTION	DETAIL	DESCRIPTION
Sd2-G		<p>GRAVEL DROP INLET PROTECTION CONSTRUCTION</p>  <p>CONSTRUCTION DETAIL D42 SPECIFICATIONS SECTION 163</p> <p>LINE CODE</p> <p>Sd2-G</p>	<p>USED FOR INLET PROTECTION WHERE HEAVY CONCENTRATED FLOWS ARE EXPECTED. STONE AND GRAVEL ARE USED TO TRAP SEDIMENT. THE SLOPE TOWARD THE INLET SHALL BE NO MORE THAN 3:1. A GUIDE FOR USE WILL BE FOR AN INLET RECEIVING A Q=3-5 cfs.</p>
Sd3		<p>SEDIMENT BASIN</p>  <p>CONSTRUCTION DETAIL SECTION 163</p> <p>LINE CODE</p> <p>Sd3</p>	<p>A BASIN EXCAVATED OR AN AREA THAT IS DAMMED. THE BASIN IS DESIGNED TO HOLD A SEDIMENT LOAD OF 67 CUBIC YARDS OF VOLUME PER ACRE OF DRAINAGE AREA. IT IS USED FOR DRAINAGE AREAS OF 3 TO 5 ACRES OR WHERE A ROADWAY CUTS OR FILLS EXCEEDS 1,000 FEET IN LENGTH. IF A SEDIMENT BASIN IS USED ON AN AREA LARGER THAN 5 ACRES SPECIAL CONSIDERATION FOR CLEAN OUT IS REQUIRED. SUFFICIENT RIGHT OF WAY OR PERMANENT EASEMENT NEEDED FOR THE BASIN AND ACCESS FOR CLEAN OUT VIA A ROUTE WITH 3:1 SLOPES OR LESS.</p> <p>SEDIMENT BASINS SHOULD ALSO BE CONSIDERED WHERE HIGH FILLS OVER 30 FEET DRAIN TO ONE LOCATION.</p>
Sr		<p>STREAM CROSSING</p>  <p>SECTION 161</p> <p>LINE CODE</p> <p>Sr</p>	<p>A TEMPORARY BRIDGE OR PIPE STRUCTURE PROTECTING A STREAM OR WATER COURSE FROM DAMAGE BY CONSTRUCTION EQUIPMENT. THIS AREA MUST BE COMPLETELY STABILIZED. THIS ITEM MUST BE DESIGNED ACCORDING TO CHAPTER 6 OF THE MANUAL FOR EROSION CONTROL IN GEORGIA</p> <p>FOR CONTRACTOR'S USE ONLY</p>

NOTE:
 1. DO NOT USE EROSION CONTROL ITEMS IN A FLOWING STREAM OR IN A TIDAL AREA BELOW HIGH TIDE.
 2. FOR ADDITIONAL INFORMATION ON THE DESIGN AND APPLICATION OF EROSION CONTROL MEASURES, SEE THE GEORGIA SOIL AND WATER CONSERVATION COMMISSION, "MANUAL FOR EROSION AND SEDIMENT CONTROL IN GEORGIA".

DEPARTMENT OF TRANSPORTATION STATE OF GEORGIA	
EROSION CONTROL LEGEND AND UNIFORM CODE SHEET SHEET 5 OF 6	
NO SCALE	JANUARY 2007
NUMBER EC-L5	DRAWING No. 52-005

UPDATED DRAWING NO. & RELOCATED ST & ST-RP CODES TO DRAWING NO. 52-006, DELETED Sg-1, Sg-2 & Sg-3 CODES. REV. Sg-1, Sg-2 AND Sg-3 GLO GLO BY	I-24-13 II-13-07 I-19-07 DATE
--	--